

Instruction Manual

No. 910 9/02



Universal Temperature Limit Controller

Model EHL023

COPYRIGHT

Copyright 2002 by Eclipse Combustion. All rights reserved worldwide. This publication is protected by federal regulation and shall not be copied, distributed, transmitted, transcribed or translated into any human or computer language, in any form or by any means, to any third parties, without the express written consent of Eclipse Combustion.

DISCLAIMER NOTICE

In accordance with the manufacture's policy of continual product improvement, the product presented in this brochure is subject to change without notice or obligation.

The material in this manual is believed adequate for the intended use of the product. If the product is used for purposes other than those specified herein, confirmation of validity and suitability must be obtained. Eclipse Combustion warrants that the product itself does not infringe upon any United States patents. Not further warranty is expressed or implied.

We have made every effort to make this manual as accurate and complete as possible. Should you find errors or omissions, please bring them to our attention so that we may correct them. In this way we hope to improve our product documentation for the benefit of our customers. Please send your corrections and comments to our Marketing Communications Manager.

LIABILITY AND
WARRANTY

It must be understood that Eclipse Combustion's liability for its product, whether due to breach of warranty, negligence, strict liability, or otherwise is limited to the furnishing of replacement parts and Eclipse Combustion will not be liable for any other injury, loss, damage or expenses, whether direct or consequential, including but not limited to loss of use, income, or damage to material arising in connection with the sale, installation, use of, inability to use, or the repair or replacement of Eclipse Combustion's products.



About this manual

AUDIENCE

This manual has been written for the people who select and install the product and the technicians who work on it. They are expected to have previous experience with this kind of equipment.

SCOPE

This manual contains essential information for the proper installation and operation of the Eclipse Universal Temperature Limit Controller.

Following the instructions in this manual should assure trouble free installation and operation. Read this manual carefully. Make sure that you understand its structure and contents. Obey all the safety instructions.

Do not deviate from any instructions or applications limits in the manual without written consent from Eclipse Combustion.

If you do not understand any part of the information in this manual, do not continue. Contact your Eclipse sales office or Eclipse Combustion, Rockford, Illinois.













HOW TO GET HELP

If you need help, you can contact your local Eclipse Combustion sales office. You can also contact Eclipse Combustion at:

Power Equipment Company
2011 Williamsburg Road
Richmond, Virginia 23231 U.S.A.
Phone: 804-236-3800
Fax: 804-236-3882
<http://www.peconet.com>

Symbol Definitions

The following table lists those symbols that may be used in this document to denote certain conditions.

Symbol	Definition
	This DANGER symbol indicates an imminently hazardous situation, which, if not avoided, will result in death or serious injury .
	This WARNING symbol indicates a potentially hazardous situation, which, if not avoided, could result in death or serious injury .
	This CAUTION symbol may be present on Control Product instrumentation and literature. If present on a product, the user must consult the appropriate part of the accompanying product literature for more information.
	This CAUTION symbol indicates a potentially hazardous situation, which, if not avoided, may result in property damage .
	WARNING PERSONAL INJURY: Risk of electrical shock. This symbol warns the user of a potential shock hazard where HAZARDOUS LIVE voltages greater than 30 Vrms, 42.4 Vpeak, or 60 Vdc may be accessible. Failure to comply with these instructions could result in death or serious injury.
	ATTENTION, Electrostatic Discharge (ESD) hazards. Observe precautions for handling electrostatic sensitive devices
	Protective Earth (PE) terminal. Provided for connection of the protective earth (green or green/yellow) supply system conductor.
	Functional earth terminal. Used for non-safety purposes such as noise immunity improvement. NOTE: This connection shall be bonded to protective earth at the source of supply in accordance with national local electrical code requirements.
	Earth Ground. Functional earth connection. NOTE: This connection shall be bonded to Protective earth at the source of supply in accordance with national and local electrical code requirements.
	Chassis Ground. Identifies a connection to the chassis or frame of the equipment shall be bonded to Protective Earth at the source of supply in accordance with national and local electrical code requirements.
	Earth Ground. Functional earth connection. NOTE: This connection shall be bonded to Protective earth at the source of supply in accordance with national and local electrical code requirements.
	Chassis Ground. Identifies a connection to the chassis or frame of the equipment shall be bonded to Protective Earth at the source of supply in accordance with national and local electrical code requirements.

Contents

1	INTRODUCTION	9
1.1	Overview	9
1.2	CE Conformity (Europe)	10
2	INSTALLATION.....	11
2.1	Overview	11
2.2	Model Number Interpretation.....	13
2.3	Preliminary Checks	13
2.4	Limit Control and Alarm Relay Contact Information	15
2.5	Mounting	16
2.6	Wiring.....	18
2.7	Wiring Diagrams	19
2.8	Limit Control Application Diagram.....	21
3	INITIAL START-UP	23
3.1	Overview	23
3.2	Powering Up the Controller	23
3.3	Operator Interface and Key Functions	24
3.4	Key Error Message.....	24
4	CONFIGURATION.....	26
4.1	Overview	26
4.2	Configuration Prompt Hierarchy.....	27
4.3	Configuration Procedure	28
4.4	Lock Set Up Group.....	29
4.5	Limit Set Up Group.....	30
4.6	Input 1 Set Up Group	31
4.7	Options Set Up Group	33
4.8	Communications Set Up Group.....	33
4.9	Alarms Set Up Group	34
4.10	Configuration Record Sheet	36
5	OPERATING THE LIMIT CONTROLLER	37
5.1	Overview	37

5.2	Operator Interface.....	38
5.3	Entering a Security Code.....	38
5.4	Lockout Feature.....	39
5.5	Monitoring Your Limit Controller	40
5.6	Alarm Setpoints.....	43
6	INPUT CALIBRATION.....	44
6.1	Overview	44
6.2	Minimum and Maximum Range Values	45
6.3	Preliminary Information	46
6.4	Input 1 Set Up Wiring	48
6.5	Input 1 Calibration Procedure	51
6.6	Restore Factory Calibration	53
7	TROUBLESHOOTING/SERVICE.....	55
7.1	Overview	55
7.2	Troubleshooting Aids.....	56
7.3	Power-up Tests	57
7.4	Status Tests.....	58
7.5	Background Tests	58
7.6	Controller Failure Symptoms	60
7.7	Troubleshooting Procedures.....	61
8	PARTS LIST	64
8.1	Exploded View	64
9	INDEX.....	66

Tables

Table 2-1	Condensed Specifications	12
Table 2-2	Preliminary Checks	14
Table 2-3	Limit Control Relay Contact Information	15
Table 2-4	Alarm Relay Contact Information	15
Table 2-5	Mounting Procedure	17
Table 2-6	Permissible Wiring Bundling	19
Table 4-1	Configuration Prompt Hierarchy	27
Table 4-2	Configuration Procedure	28
Table 4-3	LOCK Group Function Prompts	29
Table 4-4	LIMIT Group Function Prompts	30
Table 4-5	INPUT1 Group Function Prompts	31
Table 4-6	COMM Group Function Prompts	33
Table 4-7	ALARMS Group Function Prompts	34
Table 5-1	Procedure to Enter a Security Code	39
Table 5-2	Annunciators	40
Table 5-3	Error Messages	41
Table 5-4	Procedure for Displaying Alarm Setpoints	43
Table 6-1	Voltage and Resistance Equivalents for 0 % and 100 % Range Values	45
Table 6-2	Equipment Needed	47
Table 6-3	Set Up Wiring Procedure for Thermocouple Inputs Using an Ice Bath	48
Table 6-4	Set Up Wiring Procedure for Thermocouple Inputs using Thermocouple Source	48
Table 6-5	Set Up Wiring Procedure for RTD Inputs	50
Table 6-6	Set Up Wiring Procedure for Radiamatic, Milliampere, Millivolts, or Volts Inputs (Except 0-10 Volts)	50
Table 6-7	Set Up Wiring Procedure for 0 to 10 Volts	51
Table 6-8	Input 1 Calibration Procedure	52
Table 6-9	Restore Factory Calibration	54
Table 7-1	Procedure for Identifying the Software Version	57
Table 7-2	Procedure for Displaying the Status Test Results	58
Table 7-3	Background Tests	59
Table 7-4	Controller Failure Symptoms	60
Table 7-5	Troubleshooting Power Failure Symptoms	62
Table 7-6	Troubleshooting Latching Output Relay Failure	62
Table 7-7	Troubleshooting Alarm Relay Output Failure	63
Table 7-8	Troubleshooting a Keyboard Failure	63
Table 8-1	Parts Identification	64
Table 8-2	Parts Not Shown	65

Figures

Figure 1-1 EHL023 Operator Interface	10
Figure 2-1 Model Number Interpretation	13
Figure 2-2 Jumper Placements	14
Figure 2-3 Mounting Dimensions (not to scale)	16
Figure 2-4 Mounting Method	17
Figure 2-5 Composite Wiring Diagram	19
Figure 2-6 Mains Power Supply	20
Figure 2-7 Input 1 Connections	20
Figure 2-8 Electromechanical Relay Output	21
Figure 2-9 Limit Controller Application Diagram	22
Figure 3-1 Operator Interface and Key Functions	24
Figure 5-1 Operator Interface	38
Figure 6-1 Input 1 Wiring Terminals	46
Figure 6-2 Wiring Connections for Thermocouple Inputs Using an Ice Bath	48
Figure 6-3 Wiring Connections for Thermocouple Inputs Using Thermocouple Source	49
Figure 6-4 Wiring Connections for RTD (Resistance Thermometer Device)	50
Figure 6-5 Wiring Connections for Radiamatic, Milliampere, Millivolts, or Volts (Except 0-10 Volts)	51
Figure 6-6 Wiring Connections for 0 to 10 Volts	51
Figure 8-1 EHL023 Exploded View	64

1 Introduction

1.1 Overview

Introduction

EHL023 Limit Controllers accept input signals from any of several types of external sensors such as Thermocouples (T/Cs) and Resistance Temperature Detectors (RTDs). It conditions these signals, as necessary, to derive the equivalent Process Variable (PV) value that drives various circuits in the controller.

The equivalent PV signal is compared with the Limit control set point and any error signal from the differential amplifier de-energizes the coil of an electromechanical, single-pole, single-throw (SPST) limit output relay.

When de-energized, the output relay “Locks Out” and remains that way until the PV input signal drops below the High Limit Set Point or goes above the Low Limit Set Point and the controller is reset manually via the keyboard or from a remote location (Contact Input Option).

You can select normally open (N.O.) or normally closed (N.C.) Limit Relay Contacts simply by moving a jumper.

The contact of the output relay terminates at the rear terminal of the controller to which you make the appropriate field wiring connections.

A flashing “LIMIT” in the lower display indicates that the output relay is de-energized.

High Limit Controller

When the PV input signal is below the limit set point, the output relay energizes. If the PV signal *exceeds* the limit set point, the output relay de-energizes and the flashing “LIMIT” display is turned on.

When the PV signal returns to a value below the limit set point, the controller can be reset manually using the MAN-AUTO RESET key or Contact Input Option.

Low Limit Controller

When the PV input signal is above the limit set point, the output relay energizes. If the PV signal *falls below* the limit set point, the output relay de-energizes and the flashing “LIMIT” display is turned on.

When the PV signal returns to a value above the limit set point, the controller can be reset manually using the MAN-AUTO RESET key or Contact Input Option.

Operator Interface

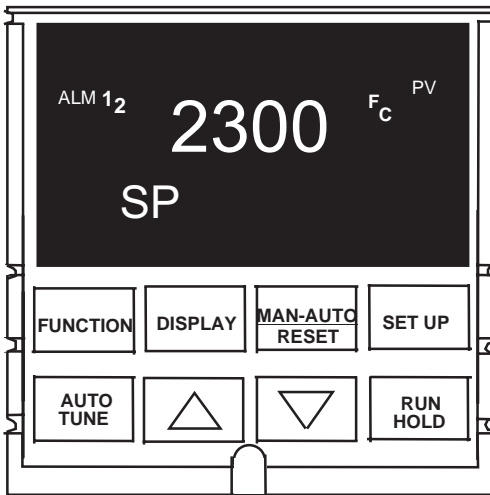

Figure 1-1 EHL023 Operator Interface

1.2 CE Conformity (Europe)

This product is in conformity with the protection requirements of the following European Council Directives: **73/23/EEC**, the Low Voltage Directive, and **89/336/EEC**, the EMC Directive. Conformity of this product with any other “CE Mark” Directive(s) shall not be assumed.

Product Classification: Class I: Permanently connected, panel-mounted Industrial Control Equipment with protective earthing (grounding). (EN61010-1).

Enclosure Rating: Panel-mounted equipment, IP 00. This controller must be panel-mounted. Terminals must be enclosed within the panel. Front panel IP 65 (IEC 529).

Installation Category (Overvoltage Category): Category II: Energy-consuming equipment supplied from the fixed installation, local level appliances, and Industrial Control Equipment. (EN61010-1)

Pollution Degree: Pollution Degree 2: Normally non-conductive pollution with occasional conductivity caused by condensation. (Ref. IEC 664-1)

EMC Classification: Group 1, Class A, ISM Equipment (EN55011, emissions), Industrial Equipment (EN50082-2, immunity)

Method of EMC Assessment: Technical File (TF)

Declaration of Conformity: 51309602-000

Deviation from the installation conditions specified in this manual, and the special conditions for CE conformity in Section 2.1, may invalidate this product’s conformity with the Low Voltage and EMC Directives.

2 Installation

2.1 Overview

Introduction

Installation of the EHL023 consists of mounting and wiring the controller according to the instructions given in this section. Read the pre-installation information, check the model number interpretation, and become familiar with your model selections, then proceed with installation.

What's in this section?

The following topics are covered in this section.

TOPIC	See Page
2.1 Overview	11
2.2 Model Number Interpretation	13
2.3 Preliminary Checks	13
2.4 Limit Control and Alarm Relay Contact Information	15
2.5 Mounting	16
2.6 Wiring	18
2.7 Wiring Diagrams	19
Composite Wiring Diagram	19
AC Line Voltage	20
Input 1 Connections	20
Relay Output	21
Electromechanical	21
2.8 Limit Controller Application Diagram	21

Pre-installation Information

If the controller has not been removed from its shipping carton, inspect the carton for damage then remove the controller.

- Inspect the unit for any obvious shipping damage and report any damage due to transit to the carrier.
- Make sure a bag containing mounting hardware is included in the carton with the controller.
- Check that the model number shown on the inside of the case agrees with what you have ordered.

Condensed Specifications

We recommends that you review and adhere to the operating limits listed in Table 2-1 when you install your controller.

Table 2-1 Condensed Specifications

Operating Limits	<p>Ambient Temperature: 32 °F to 131 °F (0 °C to 55 °C)</p> <p>Relative Humidity: 5 % to 90 % RH up to 104 °F (40 °C)</p> <p>Vibration: <i>Frequency:</i> 0 Hz to 200 Hz <i>Acceleration:</i> 0.6g</p> <p>Mechanical Shock: <i>Acceleration:</i> 5 g <i>Duration:</i> 30 ms</p> <p>Power: 90 Vac to 264 Vac, 50/60 Hz (CSA models rated to 250 Vac maximum)</p> <p>Power Consumption: 12 VA maximum</p>
Accuracy	<p>± 0.25 % of span typical ± 1 digit for display 15-bit resolution typical</p>
CE Conformity Special Conditions (Europe)	<p>Shielded twisted-pair cables are required for all analog I/O, process variable, RTD, thermocouple, dc Millivolts, low level signal, 4-20 mA, digital I/O, and computer interface circuits.</p>

2.2 Model Number Interpretation

Introduction

The single model number EHL023 specifies the complete controller and the model number interpretation as indicated in Figure 2-1:

Limit Controller Model

OUTPUT #1 (CTL1) is an Electro-mechanical relay

OUTPUT #2 (CTL2) is not installed

ALARM #1 and ALARM #2 are not installed

EXTERNAL INTERFACE (OPTION) is not installed

PV INPUT accepts T/C, RTD, Rad, mV, 0-5V, 0-20mA, 4-20mA

INPUT #2 (IN2) is not installed

90-264VAC input power

UL, CSA, CE, FM approvals

Eclipse green front bezel

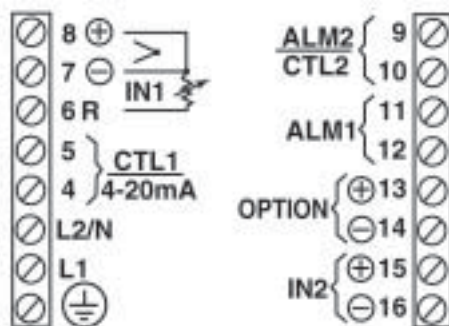

Figure 2-1 Model Number Interpretation

2.3 Preliminary Checks

Introduction

Before you install the controller, remove the chassis and make any preliminary checks necessary that are listed in Table 2-2. Figure 2-2 shows the locations for jumper placements.

Table 2-2 Preliminary Checks

Check Number	Preliminary Check	Description
1	Input I Jumper Placement	Check the internal jumper for INPUT 1 to make sure it is set for the correct input type. The jumper is located at position S101 on the printed wiring board. Figure 2-2 shows the location of the jumper and selections.
2	Limit Control Relay 1	Check the internal jumper (W101) for CONTROL . The relay is shipped as N.O. (Normally Open). Figure 2-2 shows the location of the jumper and position selections. See Table 2-3 for Limit Control Relay contact information. See Limit Relay Caution Note, Page 15.
3	Alarm Relay Action	The controller does not have ALARM relays: W201, the ALARM RELAY 1 jumper is not available. W202, the ALARM RELAY 2 jumper is not available.

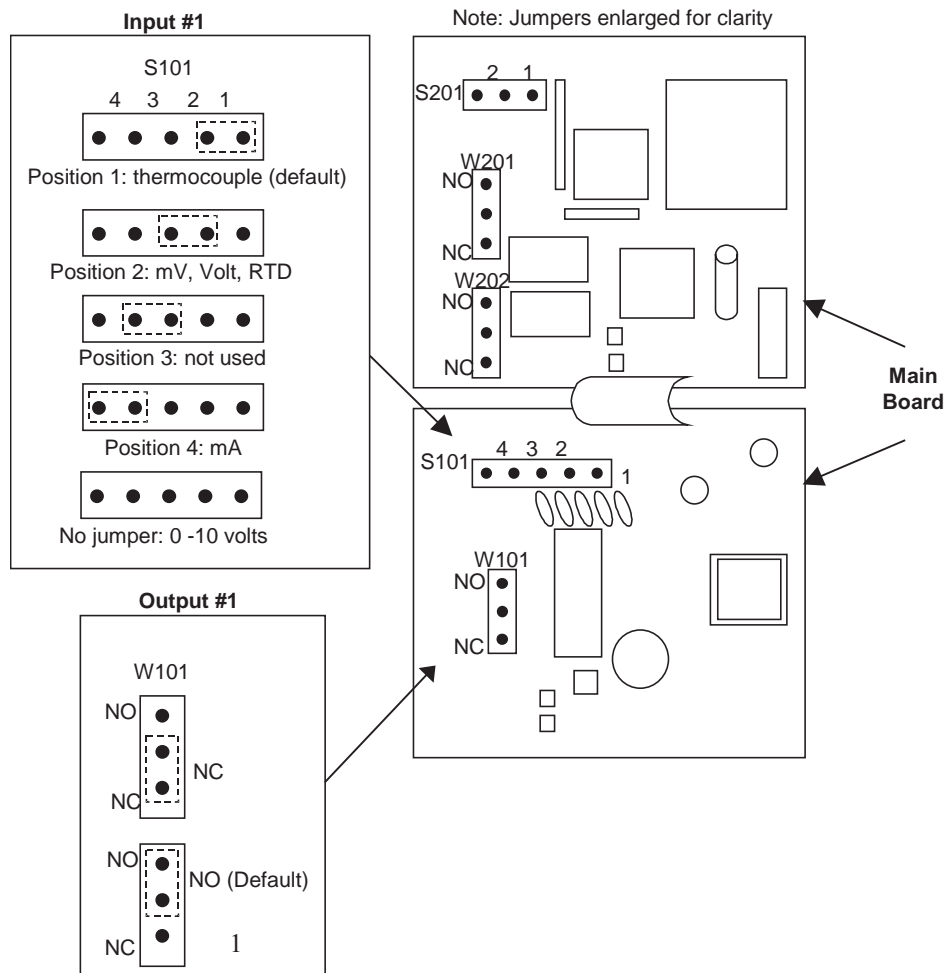

Figure 2-2 Jumper Placements

2.4 Limit Control and Alarm Relay Contact Information

Limit Control Relays

NOTICE

Limit Control relays are designed to operate in a Failsafe mode. This results in momentary (5 seconds maximum) limit action when power is initially applied, until the unit completes self-diagnostics. If power is lost to the unit, the Limit Control Relay will still function.

Table 2-3 Limit Control Relay Contact Information

Unit Power	Limit Control Relay Jumper	Variable NOT in Limit State		Variable IN Limit State	
		Relay Contact	Indicator	Relay Contact	Indicator
Off	N.O.	Open	Off	Open	Off
	N.C.	Closed		Closed	
On	N.O.	Closed	Off	Open	On
	N.C.	Open		Closed	

Alarm Relays

NOTICE

Alarm relays are not installed.

Table 2-4 Alarm Relay Contact Information

Unit Power	Alarm Relay Wiring	Relay Contact	Indicators
Off	Not Available	Open	Off
On	Not Available	Open	Off

2.5 Mounting

Physical Considerations

The controller can be mounted on either a vertical or tilted panel using the mounting kit supplied. Adequate access space must be available at the back of the panel for installation and servicing activities.

- Overall dimensions and panel cutout requirements for mounting the controller are shown in Figure 2-3.
- The controller's mounting enclosure must be grounded according to CSA standard C22.2 No. 0.4 or Factory Mutual Class No. 3820 paragraph 6.1.5.
- The front panel is moisture rated NEMA 3/IP65 (IEC) when properly installed with panel gasket.

Overall Dimensions

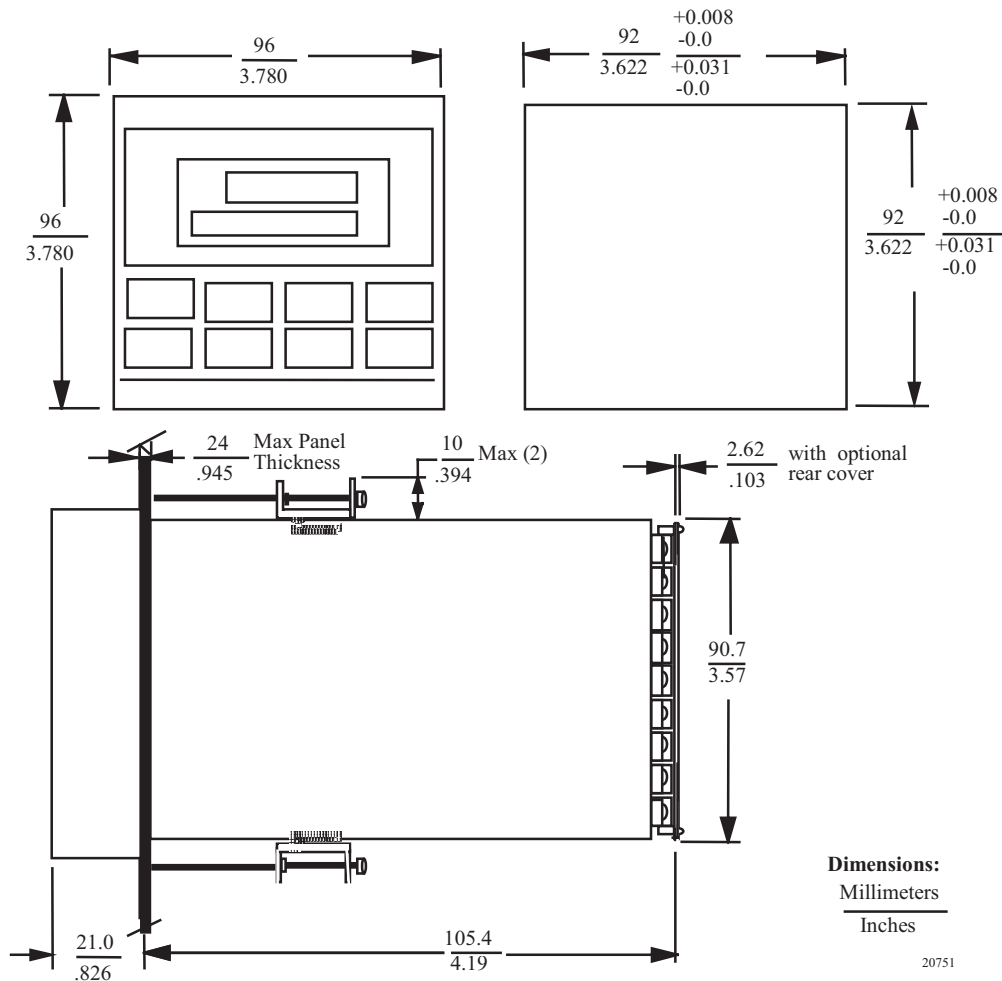

Figure 2-3 Mounting Dimensions (not to scale)

Mounting Method

Before mounting the controller, refer to the nameplate on the outside of the case and make a note of the model number. It will help later when selecting the proper wiring configuration.

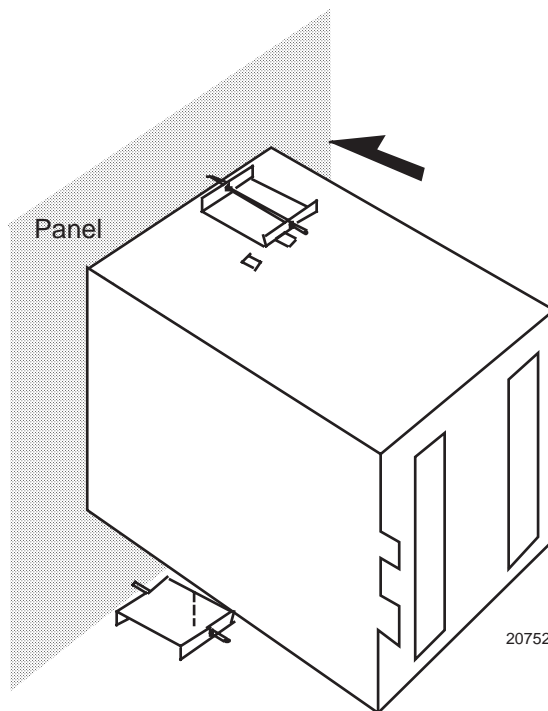

Figure 2-4 Mounting Method

Mounting Procedure

Table 2-5 Mounting Procedure

Step	Action
1	Mark and cut out the controller hole in the panel according to the dimension information in Figure 2-3.
2	Remove the screw cover and loosen the screw on the front of the controller. Pull the chassis out of the case.
3	Orient the case properly and slide it through the panel hole from the front.
4	Remove the mounting kit from the shipping container and install the kit as follows: <ul style="list-style-type: none"> • Install the screws into the threaded holes of the clips. • Insert the prongs of the clips into the two holes in the top and bottom of the case. • Tighten both screws to secure the case against the panel. • Carefully slide the chassis assembly into the case, press to close, and tighten the screw. Replace the screw cover.

2.6 Wiring

Electrical Considerations



The controller is considered “rack and panel mounted equipment” per EN61010-1, Safety Requirements for Electrical Equipment for Measurement, Control, and Laboratory Use, Part 1: General Requirements. Conformity with 72/23/EEC, the Low Voltage Directive requires the user to provide adequate protection against a shock hazard. The user shall install this controller in an enclosure that limits OPERATOR access to the rear terminals.

Mains Power Supply

This equipment is suitable for connection to 90 Vac to 264 Vac, 50/60 Hz, power supply mains. It is the user’s responsibility to provide a switch and non-time delay (North America), quick-acting, high breaking capacity, Type F (Europe), 1/2A, 250V fuse(s), or circuit-breaker, as part of the installation. The switch or circuit breaker shall be located in close proximity to the controller, within easy reach of the OPERATOR. The switch or circuit breaker shall be marked as the disconnecting device for the controller.

Controller Grounding

PROTECTIVE BONDING (grounding) of this controller and the enclosure in which it is installed shall be in accordance with National and Local electrical codes. To minimize electrical noise and transients that may adversely affect the system, supplementary bonding of the controller enclosure to a local ground, using a No. 12 (4 mm²) copper conductor, is recommended.

Control/Alarm Circuit Wiring

The insulation of wires connected to the Control/Alarm terminals shall be rated for the highest voltage involved. Extra Low Voltage (ELV) wiring (input, current output, and low voltage Control/Alarm circuits) shall be separated from HAZARDOUS LIVE (>30 Vac, 42.4 V_{peak}, or 60 V_{dc}) wiring per Permissible Wiring Bundling, Table 2-6.

Electrical Noise Precautions

Electrical noise is composed of unabated electrical signals, which produce undesirable effects in measurements and control circuits.

Digital equipment is especially sensitive to the effects of electrical noise. Your controller has built-in circuits to reduce the effect of electrical noise from various sources. If there is a need to further reduce these effects:

- *Separate External Wiring*—Separate connecting wires into bundles (See Permissible Wiring Bundling - Table 2-6) and route the individual bundles through separate conduit metal trays.
Use Suppression Devices—For additional noise protection, you may want to add suppression devices at the external source. Appropriate suppression devices are commercially available.

Permissible Wiring Bundling

Table 2-6 Permissible Wiring Bundling

Bundle No.	Wire Functions
1	<ul style="list-style-type: none"> • Line power wiring • Earth ground wiring • Control relay output wiring • Line voltage alarm wiring
2	<p>Analog signal wire, such as:</p> <ul style="list-style-type: none"> • Input signal wire (thermocouple, 4 to 20 mA, etc.) <p>Digital input signals</p>
3	<ul style="list-style-type: none"> • Low voltage alarm relay output wiring • Low voltage wiring to solid state type control circuits

2.7 Wiring Diagrams

Identify Your Wiring Requirements

The following figures show the wiring to the terminals for each specific function of the limit controller.

Limit Control Application Diagram

Figure 2-9 shows the Right and Wrong way to wire your Limit Controller.

Wiring the Controller

The composite wiring diagram below guides you to the appropriate individual diagrams to wire the controller according to your requirements.

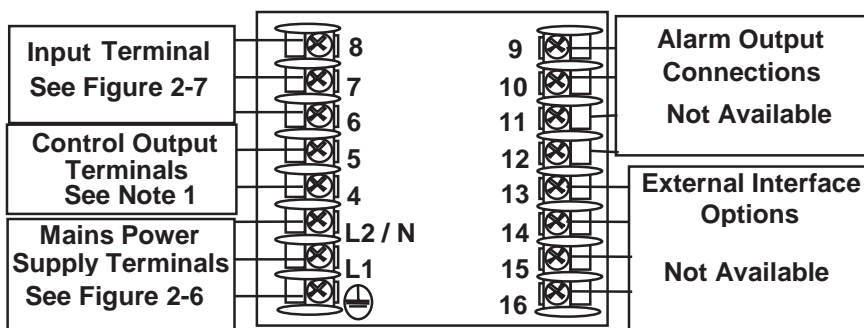

NOTE 1: Electromechanical Relay Output – See Figure 2-8

24855

Figure 2-5 Composite Wiring Diagram

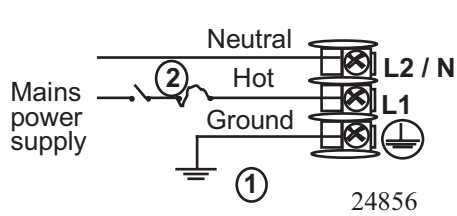

① PROTECTIVE BONDING (grounding) of this controller and the enclosure in which it is installed, shall be in accordance with National and Local electrical codes. To minimize electrical noise and transients that may adversely affect the system, supplementary bonding of the controller enclosure to a local ground, using a No. 12 (4 mm²) copper conductor, is recommended. **Before powering the controller, see “Preliminary Checks” in this section of the Product manual for switch and jumper settings.**

② Provide a switch and non-time delay (North America), quick-acting, high breaking capacity, type F (Europe), 1/2 A, 250 V fuse(s), or circuit-breaker as part of the installation.

Figure 2-6 Mains Power Supply

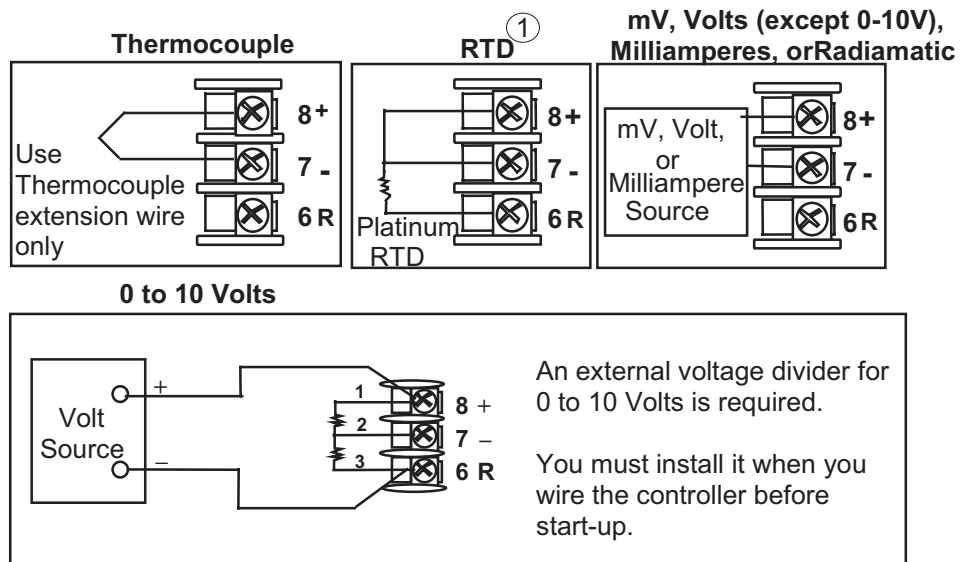

① All 3-wires from RTD must be equal length for lead length compensation.

Figure 2-7 Input 1 Connections

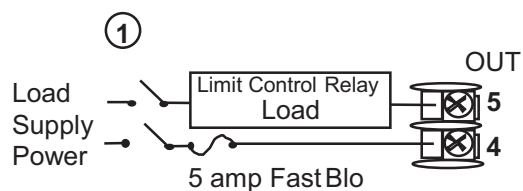

- ① Control relay is configured N.O. as shipped.
N.O. or N.C. configurations are selectable by jumpers on the Main printed wiring boards.
See “Preliminary Checks” in this section of the Product Manual for details.
Each SPST relay is rated at 5A, 120 Vac and 30 Vdc, or 2.5A for 240 Vac. User-provided fuses should be sized accordingly.

See Table 2-3 for Limit Control Relay Contact information.

Figure 2-8 Electromechanical Relay Output

2.8 Limit Control Application Diagram

Limit Controller Wiring

Figure 2-9 shows the RIGHT and WRONG way to wire your Limit Controller.

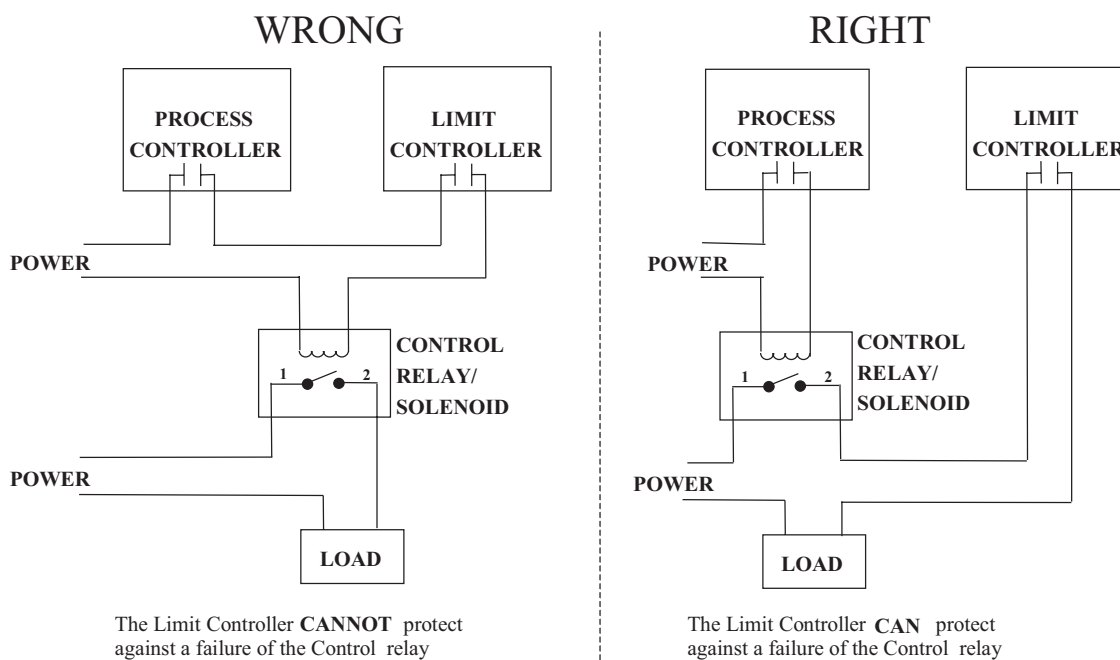

Figure 2-9 Limit Controller Application Diagram

3 Initial Start-up

3.1 Overview

This section gives you the information necessary to start up your controller prior to configuration. Review the Operator Interface portion to make sure you are familiar with the indicator definitions and key functions.

3.2 Powering Up the Controller

Apply Power

When power is applied, the controller will run three diagnostic tests. After these tests are completed, “TEST DONE” is displayed.

Test Failures

If one or more of these tests fail, a message indicating which test failed will appear in the lower display. Then, “DONE” will appear in the lower display.

3.3 Operator Interface and Key Functions

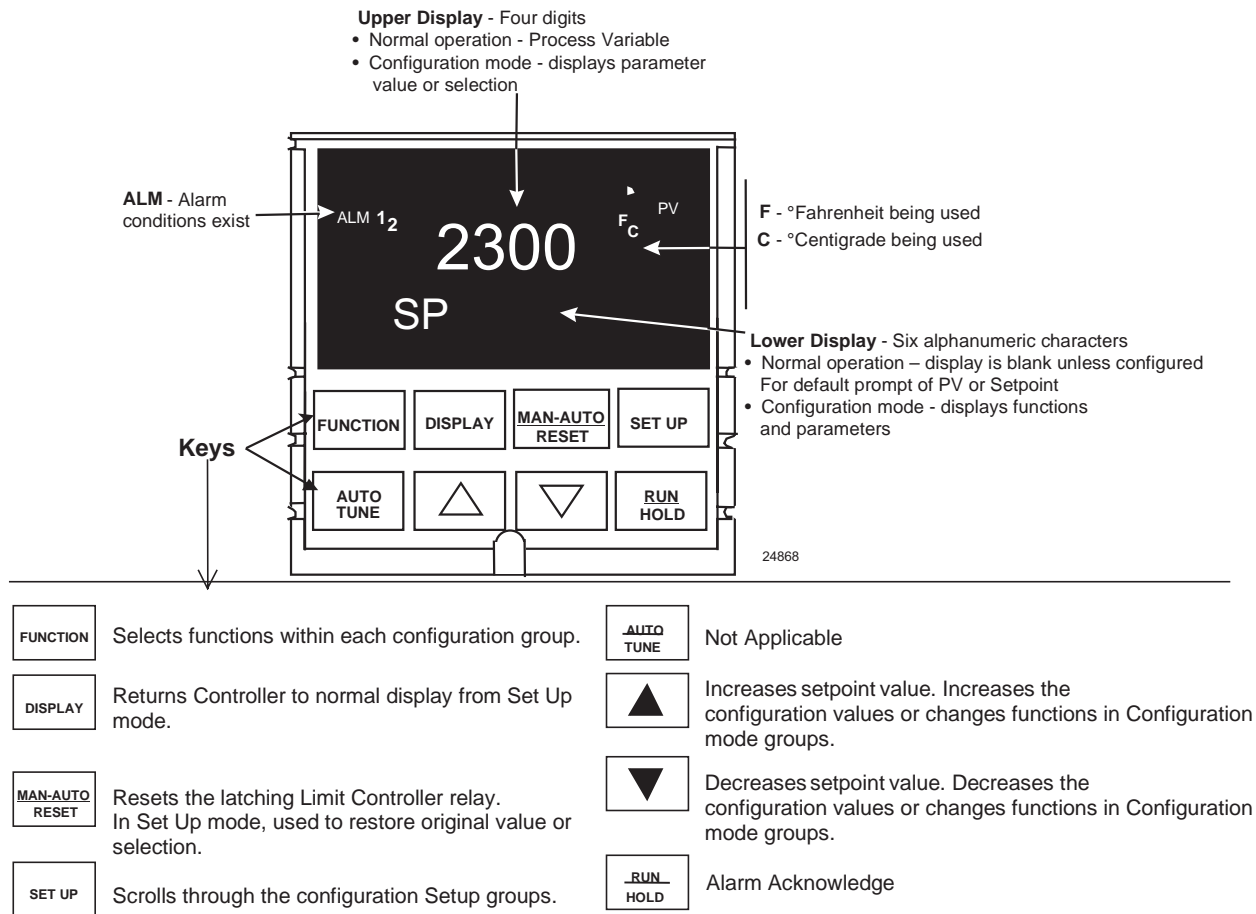

Figure 3-1 Operator Interface and Key Functions

3.4 Key Error Message

When a key is pressed and the prompt KEYERR appears in the lower display, it will be for one of the following reasons:

- parameter is not available,
- not in Set Up mode, press **[SET UP]** key first,
- key malfunction.

4 Configuration

4.1 Overview

Introduction

Configuration is a dedicated operation where you use straightforward keystroke sequences to select and establish (configure) pertinent control data best suited for your application.

To assist you in the configuration process, there are prompts that appear in the upper and lower displays. These prompts let you know what group of configuration data (Set Up prompts) you are working with and also, the specific parameters (Function prompts) associated with each group.

Figure 3-1 shows you an overview of the prompt hierarchy as they appear in the controller.

As you will see, the configuration data is divided into main Set Up groups plus prompts for calibration and prompts that show the status of the continuous background tests that are being performed

What's in this section?

The following topics are covered in this section.

TOPIC	See Page
4.1 Overview	26
4.2 Configuration Prompt Hierarchy	27
4.3 Configuration Procedure	28
4.4 Lockout Group	29
4.5 Limit Group	30
4.6 Input 1 Set Up Group	31
4.7 Options Set Up Group	33
4.8 Communications Set Up Group	33
4.9 Alarms Set Up Group	34
4.10 Configuration Record Sheet	36

4.2 Configuration Prompt Hierarchy

Table 4-1 Configuration Prompt Hierarchy

Set Up Group	Function Prompts
LOCK	SECUR LOCK
LIMIT	LOorHI POWRUP SPMAX SPMIN DISPLY
INPUT1	DECIMAL UNITS IN1TYP XMITR1 IN1 HI IN1 LO RATIO1 BIAS 1 FILTR1 BRNOUT EMISS FREQ
COM	ComSTA Communications Not Installed (reference only)
ALARMS	A1S1TY A1S2TY A2S1TY A2S2TY ALHYST BLOCK Alarms Contacts Not Installed (Display Indication Only)
STATUS	VERSON FAILSF TESTS

4.3 Configuration Procedure

Introduction

Each of the Set Up groups and their functions are pre-configured at the factory. The factory settings are shown in Table 4-3 through Table 4-7 that follow this procedure. If you want to change any of these selections or values, follow the procedure in Table 4-2. This procedure tells you the keys to press to get to any Set Up group and any associated Function parameter prompt.

Procedure

NOTICE

The prompting scrolls at a rate of 2/3 seconds when the [SET UP] or [FUNCTION] key is held in. Also, [▲] [▼] keys will move group prompts forward or backward at a rate twice as fast.

Table 4-2 Configuration Procedure

Step	Operation	Press	Result
1	Enter Set Up Mode	SET UP	Upper Display = SET Lower Display = LOCK (This is the first Set Up Group title)
2	Select any Set Up Group	SET UP	Sequentially displays the other Set Up group titles shown in the prompt hierarchy in Table 4-1. You can also use the [▲] [▼] keys to scan the Set Up groups in both directions. Stop at the Set Up group title that describes the group of parameters you want to configure. Then proceed to the next step.
3	Select a Function Parameter	FUNCTION	Upper Display = the current value or selection for the first function prompt of the selected Set Up group. Lower Display = the first Function prompt within that Set Up group. Sequentially displays the other function prompts of the Set Up group you have selected. Stop at the function prompt that you want to change, then proceed to the next step.
4	Change the Value or Selection	[▲] [▼]	Increments or decrements the value or selection that appears for the selected function prompt. If you change the value or selection of a parameter while in Set Up mode then decide not to enter it, press [MAN-AUTO/RESET] once—the original value or selection is recalled.
5	Enter the Value or Selection	FUNCTION	Enters value or selection made into memory after another key is pressed.
6	Exit Configuration	DISPLAY	Exits configuration mode and returns controller to the same state it was in immediately preceding entry into the Set Up mode. It stores any changes you have made. If you do not press any keys for 30 seconds, the controller times out and reverts to the mode and display used prior to entry into Set Up mode.

4.4 Lock Set Up Group

Introduction

The Lock Set Up group contains the Function parameters that will allow your controller to protect Configuration and Calibration data.

Because this group contains functions that have to do with Security and Lockout, it is best to configure this group last, after all the other configuration data has been loaded.

Function Prompts

Table 4-3 LOCK Group Function Prompts

Prompt	Description	Selection or Range of Setting	Factory Setting
SECUR	Security Code	0 to 4095 When "Lock" is none, this number is displayed and can be changed using the raise/lower keys	DIS
LOCK	Configuration Lockout	NONE – all parameters are read/write CAL - all parameters are read/write except Calibration CONF – configuration parameters are Read Only; no writes permitted +SP – Only the Lockout group is available for read/write. Setpoint value is Read Only.	CAL

4.5 Limit Set Up Group

Introduction

This data deals with the type of Limit Control you want, power up Logic, setpoint high and low limits, and the default display function Prompts

Table 4-4 LIMIT Group Function Prompts

Prompt	Description	Selection or Range of Setting	Factory Setting
LOorHI	Type of Limit Controller	<p>LOW - Limit Control - latching relay de-energizes when PV goes below configured setpoint; cannot be reset until PV rises above configured setpoint and [MAN-AUTO RESET] key is pressed.</p> <p>HIGH - Limit Control - latching relay de-energizes when PV goes above configured setpoint; cannot be reset until PV drops below configured setpoint and [MAN-AUTO RESET] key is pressed.</p>	HIGH
POWRUP	Power Up Logic	<p>RST - after power down, the controller latching relay will have to be reset.</p> <p>NORM - after power down, the controller will operate normally in the same mode as before power was removed unless a limit has been exceeded. If the limit was latched at power down, the unit will be in "Limit" at power up and have to be reset.</p>	NORM
SP_MAX	SP High Limit	<p>HIGH SETPOINT LIMIT - this selection prevents the setpoint from going above the value selected here. The setting must be equal to or less than the upper range of the input. <i>0 % to 100 % of input in engineering units</i></p>	2400
SP_MIN	SP Low Limit	<p>LOW SETPOINT LIMIT - this selection prevents the setpoint from going below the value selected here. The setting must be equal to or greater than the lower range of the input. <i>0 % to 100 % of input in engineering units</i></p>	0.00
DISPLY	Normal Display	<p>SP - Setpoint - if configured the setpoint will be displayed in the upper display. "SP" will appear in the lower display.</p> <p>PROC - Process Variable - PV will be displayed in the upper display.</p>	PROC

4.6 Input 1 Set Up Group

Introduction

This data deals with various parameters required to configure Input 1.

Function Prompts

Table 4-5 INPUT1 Group Function Prompts

Prompt	Description	Selection or Range of Setting	Factory Setting
DECIMAL	Decimal Point Selection	This selection determines where the decimal point appears in the display. 8888 (none) 888.8 88.88	8888
UNITS	Temperature Units	This selection will be indicated on the annunciator. ("What display of temperature do you want?") F C NONE	NONE
IN1TYP	Input 1 Actuation Type	B W H E H W L E L 100H J H 100L J L 200 K H 500 K L RADH NNMH RADI NNML N90H N90L NIC R S T H T L	K H
IN1 HI	Input 1 High Range Value	Range of Setting: -999 to 9999. floating in engineering units Linear Ranges Only	2400
IN1 LO	Input 1 Low Range Value	Range of Setting: -999 to 9999. floating in engineering units Linear Ranges Only	0.00
BIAS 1	Bias on Input 1	Range of Setting: -10 to 10 (FM approval) (Engineering Units)	0.0

Configuration

Prompt	Description	Selection or Range of Setting	Factory Setting
FILTR1	Filter for Input 1	<p>A software digital filter is provided for input 1 to smooth the input signal. You can configure the first order lag time constant from 1 to 120 seconds</p> <p>Range of Setting: 0 to 120 seconds 0 = No Filter</p>	1
BRNOUT	Burnout Protection (Sensor Break)	<p>UP - UPSCALE BURNOUT is provided for high limit control.</p> <p>DOWN - DOWNSCALE BURNOUT is provided for low limit control.</p>	UP
EMISS	Emissivity	<p>Emissivity is a correction factor applied to the Radiamatic input signal that is the ratio of the actual energy emitted from the target to the energy which would be emitted if the target were a perfect radiator.</p> <p>Range of Setting: 0.01 to 1.00 (RADH and RADI only)</p>	1.0
FREQ	Power Line Frequency	<p>Select whether your controller is operating at 60 Hz or 50 Hz.</p> <p>60 50</p>	60
		<p>NOTICE</p>	
		<p>Failure to set this parameter properly can cause normal mode noise problems in the input readings.</p>	

4.7 Options Set Up Group

Introduction

This model does not include an Options group.

4.8 Communications Set Up Group

Introduction

This model does not include the necessary hardware for communications. Settings for this group should remain set to DIS.

Function Prompts

Table 4-6 COMM Group Function Prompts

Prompt	Description	Selection or Range of Setting		Factory Setting
COMSTA	Communications State	DIS	Disabled	DIS

4.9 Alarms Set Up Group

Introduction

The prompts and indicator lights for the Alarm Outputs can be configured to visually alert an operator. The alarm relays are not physically present.

An alarm is an indication that an event that you have configured (for example—Process Variable) has exceeded one or more alarm limits. There are two alarms available. Each alarm has two setpoints. You can configure each of these two setpoints to alarm on various controller parameters.

There are two alarm output selections, High and Low. You can configure each setpoint to alarm either High or Low. These are called single alarms.

You can also configure the two setpoints to alarm on the same event and to alarm both high and low. A single adjustable Hysteresis of 0 to 100% is configurable for the alarm setpoint.

Function Prompts

Table 4-7 ALARMS Group Function Prompts

Prompt	Description	Selection or Range of Setting	Factory Setting
AxSxVA A1S1 A1S2 A2S1 A2S2	Alarm Setpointx Value X = 1 or 2	This is the value at which you want the alarm type chosen in Prompt "AxSxTY" to actuate. The value depends on what the alarm setpoint has been configured to represent. Range of Setting: within the range of the selected parameter or of the PV Span for Deviation configurations	90
AxSxTY A1S1 A1S2 A2S1 A2S2	Alarmx Setpointx Type X = 1 or 2	Select what you want Setpoint x of Alarm x to represent; it can represent the Process Variable or Deviation. NONE No Alarm PROC Process Variable DE Deviation SHED Do Not Use – Not Available P RT PV Rate of Change DI Do Not Use – Not Available	NONE
AxSxHL A1S1 A1S2 A2S1 A2S2	Alarmx Setpoint State X = 1 or 2	Select whether you want the alarm type chosen in prompt "AxSxTY" to alarm High or Low. LOW Low Alarm HIGH High Alarm	HIGH

Prompt	Description	Selection or Range of Setting	Factory Setting
ALHYST	Alarm Hysteresis	<p>A single adjustable hysteresis is provided on alarms such that when the alarm is OFF it activates at exactly the alarm setpoint; when the alarm is ON, it will not deactivate until the variable is 0.0 % to 100 % away from the alarm setpoint.</p> <p>Configure the hysteresis of the alarms based on INPUT signals as a % of input range span.</p> <p>Range of Setting: 0.0 % to 100.0 % of span</p>	0.1
ALARM1	Latching Alarm Output	<p>When configured for latching, the alarm will stay on, after the alarm condition ends, until the [RUN/HOLD] key is pressed.</p> <p>NO L Non Latching LACH Latching</p>	NO L
BLOCK	Alarm Blocking	<p>Alarm Blocking prevents nuisance alarms when the controller is first powered up. The alarm is suppressed until the parameter gets to the non-alarm limit or band. Alarm blocking affects both alarm setpoints.</p> <p>DIS Disable Blocking BK1 Block Alarm 1 only BK2 Block Alarm 2 only BK12 Blocks both Alarms</p>	DIS

4.10 Configuration Record Sheet

Enter the value or selection for each prompt on this sheet so you will have a record of how your controller was configured.

Group Prompt	Function Prompt	Value or Selection	Factory Setting	Group Prompt	Function Prompt	Value or Selection	Factory Setting
LOCK	SECUR LOCK	_____	DIS CAL	COM	ComSTA (NOT AVAILABLE)	_____	DIS
LIMIT	LOW or HIGH POWRUP SP MAX SP MIN DISPLY	_____ _____ _____ _____	HIGH NORM 2400 0.00 PROC				
INPUT1	DECMAL UNITS IN1TYP XMITR1 IN1 HI IN1 LO BIAS 1 FILTR1 BRNOUT EMIS FREQ DISPLY	_____ _____ _____ _____ _____ _____ _____ _____ _____ _____	8888 NONE KH LIN 2400 0.00 0.0 1 UP 1.0 60	ALARMS	A1S1VA A1S2VA A2S1VA A2S2VA A1S1TY A1S1TY A2S1TY A2S2TY A1S1HL A1S2HL A2S1HL A2S2HL ALHYST ALARM1 BLOCK	_____ _____ _____ _____ _____ _____ _____ _____ _____ _____ _____ _____ _____ _____ _____ _____	90 90 90 90 NONE NONE NONE NONE HIGH HIGH HIGH HIGH 0.1 NOL DIS

5 Operating the Limit Controller

5.1 Overview

Introduction

This section gives you all the information necessary to help you monitor your controller including an Operator Interface overview, how to lockout changes to the controller, entering a security code, and monitoring the displays.

What's in this section?

The following topics are covered in this section.

TOPIC	See Page
5.2 Operator Interface	38
5.3 Entering A Security Code	39
5.4 Lockout Feature	38
5.5 Monitoring The Limit Controller	40
0 How to Operate Your Limit Controller	42
5.6 Alarm Setpoints	43

5.2 Operator Interface

Introduction

Figure 5-1 is a view of the Operator Interface. A description of the displays and indicators is included.

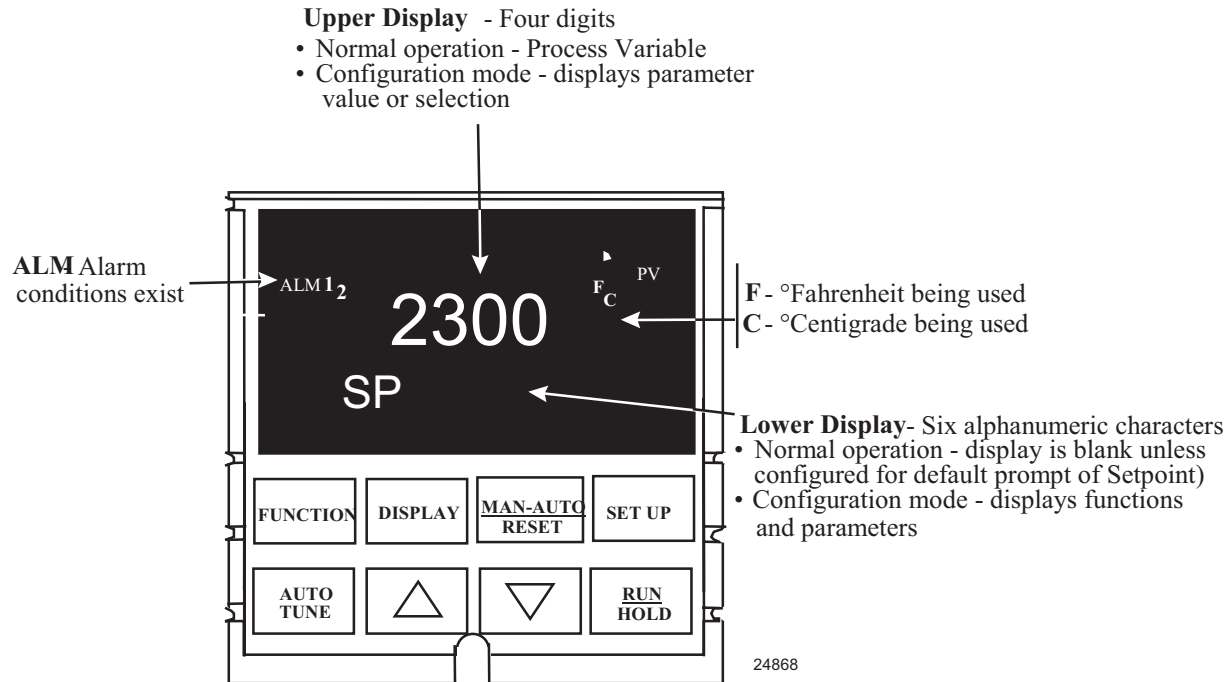

Figure 5-1 Operator Interface

5.3 Entering a Security Code

Introduction

The level of keyboard lockout may be changed in the Set Up mode. However, knowledge of a security code number (0 to 4095) may be required to change from one level of lockout to another. When a controller leaves the factory, it has a security code of 0, which permits changing from one lockout level to another without entering any other code number.

Procedure

If you require the use of a security code, select a number from 0001 to 4095 and enter it when the lockout level is configured as NONE. Thereafter, that selected number must be used to change the lockout level from something other than NONE.

NOTICE

Write the number on the Configuration Record Sheet in the configuration section so you will have a permanent record.

Table 5-1 Procedure to Enter a Security Code

Step	Operation	Press	Result
1	Enter Set Up Mode	SET UP	Upper Display = SET UP Lower Display = LOCK
2	Select any Set Up Group	FUNCTION	Upper Display = 0 Lower Display = SECUR
3	Security Code Entry	[σ] [τ]	To enter a four digit number in the upper display (0001 to 4095) This will be your security code.

5.4 Lockout Feature

Introduction

The lockout feature in the EHL023 is used to inhibit changes (via keyboard) of certain functions or parameters by unauthorized personnel.

Lockout levels

There are different levels of Lockout depending on the level of security required. These levels are:

- NONE No Lockout. All groups Read/Write.
- CAL All groups Read/Write except Calibration
- CONF Configuration parameters are Read only. No writes permitted. Calibration Group is not available.
- +SP Only the Lockout group is available for Read/Write. Setpoint value is Read Only.

See *Subsection 4.4- Lockout Parameters Set Up Group* prompts to select one of the above.

Key error

When a key is pressed and the prompt “Key Error” appears in the lower display, it will be for one of the following reasons:

- Parameter not available or locked out
- Not in setup mode, press **[SET UP]** key first

5.5 Monitoring Your Limit Controller

Annunciators

The following annunciator functions have been provided to help monitor the controller:

Table 5-2 Annunciators

Annunciator	Indication
ALM 1 2	<i>A visual indication of each alarm</i> Blinking 1 indicates alarm latched and needs to be acknowledged before extinguishing when the alarm condition ends
F or C	<i>A visual indication of the temperature units</i> F—Degrees Fahrenheit C—Degrees Celsius

Display Mode

The displays and indicators on the operator interface, as shown in Figure 5-1, let you see what is happening to your process and how the Limit Controller is responding.

The Limit Controller is a single line display device except when in the SETUP mode or the **[DISPLAY]** key is pressed or limit has been reached.

This display can be one of two types:

Display Mode 1

The PV is displayed in the upper display and the lower display is blank.

Display Mode 2

The setpoint is displayed in the upper display and “SP” is displayed in the lower display.

Viewing the operating parameters

Press the **[DISPLAY]** key to scroll through the operating parameters:

SP* Setpoint

PV Process Variable

* You can press ▲ or ▼ to change the value of this parameter.

Timing out from lower display

The normal variable display will automatically return in the upper display if the **[DISPLAY]** key is not pressed for 30 seconds.

Diagnostic Error Messages

The EHL023 performs background tests to verify data and memory integrity. If there is a malfunction, an error message will be displayed. In the case of more than one simultaneous malfunction, the messages will be displayed sequentially on the lower display. If any of these error messages in Table 5-3 occur, refer to *Section 7 - Troubleshooting* for information to correct the failure.

Table 5-3 Error Messages

Prompt	Description
EE FAIL	Unable to write to nonvolatile memory.
IN1FL	Two consecutive failures of input 1 integration.
CNFERR	Configuration Errors—Low limit greater than high limit for PV or SP
IN1RNG	Input 1 Out-of-Range Out-of-range criteria: Linear range: ±10% out-of-range Characterized range: ±1% out-of-range
PV LIM	PV Out-of-Range PV = PV + PV bias
FAILSF	Failsafe — conditions for Failsafe are: ... EEROM Test Failed ... Scratch Pad RAM Test Failed ... Configuration Test Failed Check the “Status” group.

High and Low Limit Indication

When the high or low limit is exceeded, the lower display indicates the word “**LIMIT**” (blinking). The PV is indicated in the upper display. This will continue as long as the Out-of-Limit condition exists.

The Limit Relay *cannot* be reset while a Limit condition exists.

The latching relay cannot be reset until the PV input signal drops below the high set point (High Limit) or rises above the low set point (Low Limit) value. The flashing “LIMIT” message will go away after the Out-of-Limit condition no longer exists AND you press the [MAN-AUTO RESET] key.

Operating Your Limit Controller

Operating Principles

The Limit Controller accepts signals from such sources as Thermocouples (T/Cs), Resistance Temperature Detectors (RTDs), and Radiamatics. The equivalent PV signal is compared with the Limit set point. If above (Hi Limit) or below (Lo Limit), a limit output relay is de-energized. When de-energized, the output relay locks out and remains in this state until the PV input signal drops below the high limit setpoint or rises above the low limit setpoint, and the controller is reset manually from the front of the controller or through an optional external switch.

Check the configuration

Make sure the Limit Controller has been configured to handle your process needs. Refer to *Section 4 - Configuration* for prompts and parameters.

- Input Parameters
- Alarm Set Points and type
- Limit Control Type - high or low
- Power-up Logic - Reset (relay on) or Normal (same as before power down)
- Lockout selection

Power Up Logic

Configurable power-up logic lets you select the latching output relay to require “RESET” or to provide normal operation at power-up. If power to the limit controller fails and power is reapplied, the controller goes through power up tests then starts in one of the following configurable conditions:

- If you configured RST at setup group “LIMIT”, the lower display will blink “LIMIT” at power up. This will require reset via the **[MAN-AUTO RESET]** key or external switch to obtain normal operation.
- If you configured NORM at setup group “LIMIT”, the display and limit controller will function normally at power up, (that is, no reset of the latching relay is required unless a limit has been exceeded). If the limit was latched when power went down, the unit will be in limit at power-up.

Refer to *Section 4 - Configuration, subsection 4.5 Limit Parameters Set Up Group* under SET UP prompt “LIMIT” and make your selection at FUNCTION prompt “POWRUP.”

How to Reset the Latching Relay

The latching relay cannot be reset until the PV input signal drops below the high set point (High Limit) or rises above the low set point (Low Limit) value.

Press the **[MAN-AUTO RESET]** key.

5.6 Alarm Setpoints

Introduction

An alarm consists of a relay contact and an operator interface indication. The alarm relay is de-energized if setpoint 1 or setpoint 2 is exceeded.

The alarm relay is energized when the monitored value goes into the allowed region by more than the hysteresis.

The relay contacts can be wired for normally open (NO) energized or normally closed (NC) de-energized using internal jumper placement. See Table 2-4 in the *Section 2 – Installation* for alarm relay contact information.

There are four alarm setpoints, two for each alarm. The type and state (High or Low) is selected during configuration. See *Subsection 4– Configuration* for details.

Alarm Setpoints Display

Table 5-4 Procedure for Displaying Alarm Setpoints

Step	Operation	Press	Result
1	Select Alarm Set-up Group	SET UP	Until you see: <i>Upper Display = SET</i> <i>Lower Display = ALARMS</i>
2	Access the Alarm Setpoint Values	FUNCTION	To successively display the alarm setpoints and their values. Their order of appearance is shown below. <i>Upper Display = (the alarm setpoint value)</i> <i>Range values are within the range of the selected parameters:</i> <i>DE (Deviation) value = within Input 1 Span</i> <i>PV (Process variable) value = Within Input 1 range</i>
3	Change a value	[▲] [▼]	To change any alarm setpoint value in the upper display
4	Return to Normal Display	DISPLAY	

6 Input Calibration

6.1 Overview

Introduction

This section describes the field calibration procedures for Input 1.

- Every EHL023 Limit controller contains all input actuation ranges, which are fully factory-calibrated and ready for configuration to range by the user.
- However, these procedures can be implemented if the factory calibration of the desired range is not within specification.

CAUTION

FIELD CALIBRATION WILL BE LOST

The field calibration will be lost if a change in input type configuration is implemented at a later time. The original factory calibration data remains available for later use after a field calibration is done. See subsection 6.6 if you want to restore factory calibration.

What's in this section?

The following topics are covered in this section.

TOPIC	See Page
6.1 Overview	44
6.2 Minimum and Maximum Range Values	45
6.3 Preliminary Information	46
6.4 Input #1 Set Up Wiring	48
6.5 Input #1 Calibration Procedure	51
6.6 Restore Factory Calibration	53



WARNING—SHOCK HAZARD



INPUT CALIBRATION MAY REQUIRE ACCESS TO HAZARDOUS LIVE CIRCUITS, AND SHOULD ONLY BE PERFORMED BY QUALIFIED SERVICE PERSONNEL. MORE THAN ONE SWITCH MAY BE REQUIRED TO DE-ENERGIZE UNIT BEFORE CALIBRATION.

Failure to comply with these instructions could result in death or serious injury.

Calibration Steps

Use the following steps when calibrating an input.

Step	Action
1	Find the minimum and maximum range values for your PV input range from Table 6-1.
2	Disconnect the field wiring and find out what equipment you will need to calibrate.
3	Wire the calibrating device to your controller according to the set up wiring instructions for your particular input (Subsection 6.4).
4	Follow the calibration procedure given for Input #1 (Subsection 6.5).

6.2 Minimum and Maximum Range Values

Select the Range Values

You should calibrate the controller for the minimum (0 %) and maximum (100 %) range values of your particular controller. Select the Voltage or Resistance equivalent for 0 % and 100 % range values from Table 6-1. Use these values when calibrating your controller.

Table 6-1 Voltage and Resistance Equivalents for 0 % and 100 % Range Values

Sensor Type	PV Input Range		Range Values	
	°F	°C	0 %	100 %
Thermocouples				
B	0 to 3300	-18 to 1816	-0.100 mV	13.769 mV
E	-454 to 1832	-270 to 1000	-9.835 mV	76.373 mV
E (low)	-200 to 1100	-129 to 593	-6.472 mV	44.455 mV
J	0 to 1600	-18 to 871	-0.886 mV	50.060 mV
J (low)	20 to 770	-7 to 410	-0.334 mV	22.400 mV
K	0 to 2400	-18 to 1816	-0.692 mV	52.952 mV
K (low)	-20 to 1000	-29 to 538	-1.114 mV	22.255 mV
NiNiMoly (NNM68)	32 to 2500	0 to 1371	0.000 mV	71.330 mV
NiNiMoly (low)	32 to 1260	0 to 682	0.000 mV	31.820 mV
NiMo-NiCo (NM90)	32 to 2500	0 to 1371	0.000 mV	71.773 mV
NiMo-NiCo (low)	32 to 1260	0 to 682	0.000 mV	31.825 mV
Nicrosil Nisil (Nic)	0 to 2372	-18 to 1300	-0.461 mV	47.513 mV
R	0 to 3100	-18 to 1704	-0.090 mV	20.281 mV
S	0 to 3100	-18 to 1704	-0.092 mV	17.998 mV
T	-300 to 700	-184 to 371	-5.341 mV	19.097 mV

Sensor Type	PV Input Range		Range Values	
	°F	°C	0 %	100 %
T (low)	-200 to 500	-129 to 260	-4.149 mV	12.574 mV
W5W26	0 to 4200	-18 to 2315	-0.234 mV	37.075 mV
W5W26 (low)	0 to 2240	-18 to 1227	-0.234 mV	22.283 mV
Radiamatic				
Type RH	0 to 3400	-18 to 1871	0.00 mV	57.12 mV
Type RI*	0 to 3200	-18 to 1760	0.00 mV	60.08 mV
RTD (IEC Alpha=0.00385)				
100 ohms	-300 to 1200	-184 to 649	25.18 ohms	274.96 ohms
100 ohms (low)	-300 to 300	-184 to 149	25.18 ohms	156.90 ohms
200 ohms	-300 to 900	-184 to 482	50.36 ohms	549.92 ohms
500 ohms	-300 to 900	-184 to 482	125.90 ohms	1374.80 ohms
Linear				
Milliamps (impedance – 249 Ω)	4 to 20 mA 0 to 20 mA		4.00 mA 0.00 mA	20.00 mA 20.00 mA
Millivolts	0 to 10 mV 0 to 50 mV 0 to 100 mV		0.00 mV 0.00 mV 0.00 mV	10.00 mV 50.00 mV 100.00 mV
Volts	1 to 5 Volts 0 to 2 Volts 0 to 5 Volts 0 to 10 Volts*		1.00 Volts 0.00 Volts 0.00 Volts 0.00 Volts	5.00 Volts 2.00 Volts 5.00 Volts 10.00 Volts

6.3 Preliminary Information

Disconnect the Field Wiring

Tag and disconnect any field wiring connected to the input 1 terminals on the rear of the controller.

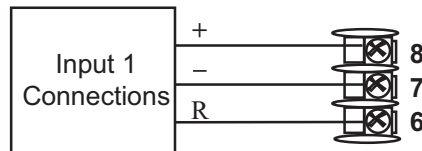

Figure 6-1 Input 1 Wiring Terminals

Check the Jumper for Input 1

Before you calibrate Input #1, check the internal jumper for Input 1 to make sure it is set for the correct input type. The jumper is located at position S101 on the printed wiring board. Figure 2-2 shows the location of the jumper and position selections.

Equipment Needed

Table 6-2 lists the equipment you will need to calibrate the specific types of inputs that are listed in the table. You will need a screwdriver to connect these devices to your controller.

Table 6-2 Equipment Needed

Type of Input	Equipment Needed
Thermocouple Inputs (Ice Bath)	<ul style="list-style-type: none"> • A calibrating device with ± 0.02 % accuracy for use as a signal source such as a Millivolts source. • Thermocouple extension wire that corresponds with the type of thermocouple that will be used with the controller input. • Two insulated copper leads for connecting the thermocouple extension wire from the ice baths to the mV source. • Two containers of crushed ice.
Thermocouple Inputs (T/C Source)	<ul style="list-style-type: none"> • A calibrating device with ± 0.02 % accuracy for use as a signal source such as a millivolt source. • Thermocouple extension wire that corresponds with the type of thermocouple that will be used with controller input.
RTD (Resistance Thermometer Device)	<ul style="list-style-type: none"> • A decade box, with ± 0.02 % accuracy, capable of providing stepped resistance values over a minimum range of 0 ohms to 1400 ohms with a resolution of 0.1 ohm. • Three insulated copper leads of equal length for connecting the decade box to the controller.
Milliamperes, Millivolts, Volts, and Radiamatic	<ul style="list-style-type: none"> • A calibrating device with ± 0.02 % accuracy for use as a signal source. • Two insulated copper leads for connecting the calibrator to the controller. • Place current source at zero before switching ON. • Do not switch current sources OFF/ON while connected to the EHL023 input.

NOTICE

For Radiamatic inputs only, set Emissivity value to 1.0. See *Section 4.6 – Configuration Set Up* prompt INPUT1, function prompt EMISS.

6.4 Input 1 Set Up Wiring

Thermocouple Inputs Using an Ice Bath

Refer to Figure 6-2 and wire the controller according to the procedure given in Table 6-3. Make sure the jumper at S101 is in the #1 position (Figure 2-2).

Table 6-3 Set Up Wiring Procedure for Thermocouple Inputs Using an Ice Bath

Step	Action
1	Connect the copper leads to the calibrator.
2	Connect a length of thermocouple extension wire to the end of each copper lead and insert the junction points into the ice bath.
3	Connect the thermocouple extension wires to the terminals for Input #1. See Figure 6-2.

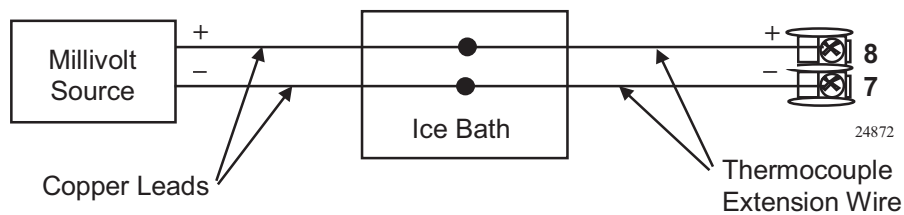

Figure 6-2 Wiring Connections for Thermocouple Inputs Using an Ice Bath

Thermocouple Inputs Using a Thermocouple Source

Refer to Figure 6-3 and wire the controller according to the procedure given in Table 6-4. Make sure the jumper at S101 is in the #1 position (Figure 2-2).

Table 6-4 Set Up Wiring Procedure for Thermocouple Inputs using Thermocouple Source

Step	Action
1	Connect the thermocouple extension wires to the terminals for Input #1 as shown in Figure 6-3.

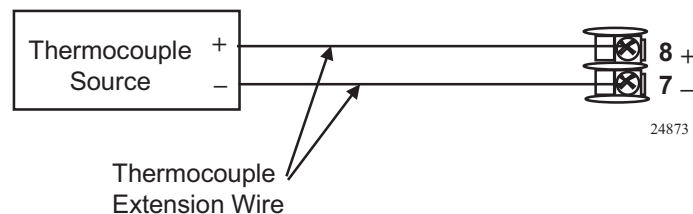

Figure 6-3 Wiring Connections for Thermocouple Inputs Using Thermocouple Source

RTD Inputs

Refer to Figure 6-4 and wire the controller according to the procedure given in Table 6-5. Make sure the jumper at S101 is in the #2 position (Figure 2-2).

Table 6-5 Set Up Wiring Procedure for RTD Inputs

Step	Action
1	Connect the copper leads from the calibrator to the Input #1 terminals as shown in Figure 6-4.
2	Place current source at zero before switching on.
3	Do not switch current sources ON/OFF while connected to the EHL023 input.

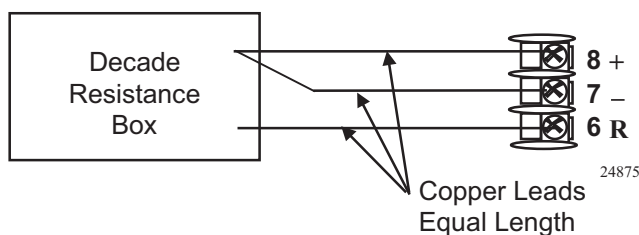

Figure 6-4 Wiring Connections for RTD (Resistance Thermometer Device)

Radiamatic, Millivolts, Milliampere, or Volts

Refer to Figure 6-5 and wire the controller according to the procedure given in Table 6-6. Make sure the jumper at S101 is in the #2 position for, mV, Volts, or the #4 position for mA (Figure 2-2).

Table 6-6 Set Up Wiring Procedure for Radiamatic, Milliampere, Millivolts, or Volts Inputs (Except 0-10 Volts)

Step	Action
1	Connect the copper leads from the calibrator to the Input #1 terminals as shown in Figure 6-5.
2	Place current source at zero before switching on.
3	Do not switch current sources ON/OFF while connected to the EHL023 input.

NOTICE

For Radiamatic inputs only, set Emissivity value to 1.0. See *Section 4.6 – Configuration Set Up* prompt INPUT1, function prompt EMISS.

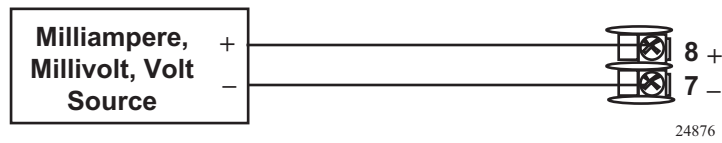

Figure 6-5 Wiring Connections for Radiamatic, Milliampere, Millivolts, or Volts (Except 0-10 Volts)

0 to 10 Volts

Refer to Figure 6-6 and wire the controller according to the procedure given in Table 6-7. Make sure the jumper at S101 is in parked position (Figure 2-2).

Table 6-7 Set Up Wiring Procedure for 0 to 10 Volts

Step	Action
1	Connect the copper leads from the calibrator to the Input #1 terminals as shown in Figure 6-6.
2	Place current source at zero before switching on.
3	Do not switch current sources ON/OFF while connected to the EHL023 input.

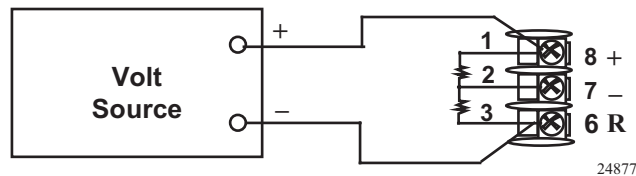

Figure 6-6 Wiring Connections for 0 to 10 Volts

6.5 Input 1 Calibration Procedure

Preliminary Steps

- Apply power and allow the controller to warm up for 30 minutes before you calibrate.
- Please read *Section 6.4 – Input 1 Set Up Wiring* before beginning the procedure.
- **Make sure you have LOCK set to NONE. See Section 4.5 - Limit Set Up Group.**
- See Table 6-1 for Voltage vs. Resistance equivalents or 0 % and 100 % range values.

CAUTION

For linear inputs, avoid step changes in inputs. Vary smoothly from initial value to final 100 % value.

Procedure

The calibration procedure for Input #1 is listed in Table 6-8.

Table 6-8 Input 1 Calibration Procedure

Step	Operation	Press	Result						
1	Enter Calibration Mode	<div style="border: 1px solid black; padding: 2px; display: inline-block;">SET UP</div> until you see <div style="border: 1px solid black; padding: 2px; display: inline-block;">FUNCTION</div>	Upper Display = CAL Lower Display = INPUT1 You will see: Upper Display = DIS Lower Display = CALIN1 <div style="border: 1px solid black; padding: 2px; display: inline-block; width: 20px; text-align: center;">▲</div> The calibration sequence is enabled and you will see: Upper Display = BEGN Lower Display = CALIN1 At the completion of the sequence, the selection automatically reverts to disable.						
2	Calibrate 0 %	<div style="border: 1px solid black; padding: 2px; display: inline-block;">FUNCTION</div>	You will see: Upper Display = APLY Lower Display = IN1ZRO <ul style="list-style-type: none"> • Adjust your calibration device to an output signal equal to the 0 % range value for your particular input sensor. See Table 6-1 for Voltage, Degrees, or Resistance equivalents for 0 % range values. • Wait 15 seconds, and then go to the next step. 						
3	Calibrate 100 %	<div style="border: 1px solid black; padding: 2px; display: inline-block;">FUNCTION</div>	You will see: Upper Display = APLY Lower Display = IN1SPN <ul style="list-style-type: none"> • Adjust your calibration device to an output signal equal to the 100 % range value for your particular input sensor. See Table 6-1 for Voltage, Degrees, or Resistance equivalents for 100 % range values. • Wait 15 seconds, and <table border="1" style="width: 100%; border-collapse: collapse;"> <thead> <tr> <th style="width: 70%;">If ...</th> <th>Then ...</th> </tr> </thead> <tbody> <tr> <td>you are calibrating a Thermocouple input</td> <td>go to step 4</td> </tr> <tr> <td>you are calibrating other than a Thermocouple input</td> <td>go to step 5</td> </tr> </tbody> </table>	If ...	Then ...	you are calibrating a Thermocouple input	go to step 4	you are calibrating other than a Thermocouple input	go to step 5
If ...	Then ...								
you are calibrating a Thermocouple input	go to step 4								
you are calibrating other than a Thermocouple input	go to step 5								

Step	Operation	Press	Result
4	Check the Cold Junction Temperature	FUNCTION	<p>The calculations for zero and span are now stored and you will see:</p> <p><i>Upper Display</i> = The cold junction temperature at the rear terminals <i>Lower Display</i> = CJTEMP</p> <p>The value in the upper display is in tenths of a degree. It is the current reading of the temperature as measured at the thermocouple terminals and recognized by the controller. You can change this value, if it is in error, using the [σ] [τ] keys.</p> <div style="border: 1px solid black; padding: 5px; margin-top: 10px;"> <p>NOTICE</p> <p>The accuracy of the controller is directly affected by the accuracy of this value. Change this value only if the zero and span calibration procedures did not bring the controller within the specified accuracy requirements.</p> </div>
5	Exit the Calibration Mode	<p>FUNCTION</p> <p>then</p> <p>DISPLAY</p>	The controller stores the calibration constants and exits the calibration mode.

6.6 Restore Factory Calibration

Introduction

The factory calibration constants for all the input actuation types that can be used with the controller are stored in its nonvolatile memory. Thus, you can quickly restore the “Factory Calibration” for a given input actuation type by simply changing the actuation type to another type and then changing it back to the original type.

Refer to Table 6-9 Restore Factory Calibration for procedure.

NOTICE

A restored factory calibration overwrites any previous field calibration done for the input and may change the High and Low Range Limits. Be sure to protect any field calibration from accidental overwrites by configuring the appropriate LOCKOUT selection after calibration. See the *Section 4 - Configuration* for specific instructions to set the lockout.

Table 6-9 Restore Factory Calibration

Step	Operation	Press	Result
1	Set LOCKOUT to NONE	SET UP	until you see: <i>Upper Display</i> = SET UP <i>Lower Display</i> = LOCK
		FUNCTION	Until you see: <i>Upper Display</i> = one of the following: NONE – all parameters are read/write CAL - all parameters are read/write except Calibration CONF – configuration parameters are Read Only; no writes permitted +SP – Only the Lockout group is available for read/write. Setpoint value is Read Only. <i>Lower Display</i> = LOCK
		[▲][▼]	Until NONE is in the upper display
2	Enter INPUT 1 Setup Group	SET UP	until you see: <i>Upper Display</i> = SET UP <i>Lower Display</i> = INPUT 1
		FUNCTION	until you see: <i>Upper Display</i> = the current selection <i>Lower Display</i> = IN1TYP
		[▲][▼]	to change the current selection to another selection
3	Scroll through Functions	FUNCTION	until the lower display rolls through the rest of the functions and returns to <i>Upper Display</i> = the new selection <i>Lower Display</i> = IN1TYP
		[▲][▼]	until you change the input selection in the upper display back to the proper selection. You will see: <i>Upper Display</i> = Original Input Selection that matches your type of sensor. <i>Lower Display</i> = IN1TYP
4	Return to Normal Operation	DISPLAY	to return to Normal operating mode. The factory calibration will be restored. If the problem is not corrected, contact the provider.

7 Troubleshooting/Service

7.1 Overview

Introduction

Instrument performance can be adversely affected by installation and application problems as well as by hardware problems. We recommend that you investigate the problems in the following order:

- installation related problems
- application related problems
- hardware and software related problems

and use the information presented in this section to solve them. If a replacement of any part is required, follow the procedures listed under “Parts Replacement Procedures.”

What's in this section?

The following topics are covered in this section.

TOPIC		See Page
7.1	Overview	55
7.2	Troubleshooting Aids <ul style="list-style-type: none"> • Overall Error Messages • Controller Failure Symptoms • Determining the Software Version Number 	56
7.3	Power-up Tests	57
7.4	Status Tests	58
0	Background Tests	58
7.6	Controller Failure Symptoms	60
7.7	Troubleshooting Procedures <ul style="list-style-type: none"> • Power Failure • Alarm Relay Output Failure • Keyboard Failure 	61

Installation related problems

Read the Installation section in this manual to make sure the EHL023 has been properly installed. The installation section provides information on protection against electrical noise, connecting external equipment to the controller, and shielding and routing external wiring.

NOTICE

System noise induced into the controller will result in diagnostic error messages recurring. If the diagnostic error messages can be cleared, it indicates a “soft” failure and is probably noise related.

If system noise is suspected, completely isolate the controller from all field wiring. Use calibration sources to simulate PV and check all controller functions.

Application related problems

Review the application of the controller; then, if necessary, direct your questions to the local sales office.

Hardware and software related problems

Use the troubleshooting error message prompts and controller failure symptoms to identify typical failures that may occur in the controller. Follow the troubleshooting procedures to correct them.

7.2 Troubleshooting Aids

Overall error messages

An error message can occur:

- at power-up, see Subsection 7.3
- when the Status Tests are requested. See Subsection 7.4
- during continuous background tests while in normal operation. See Subsection 0

Controller failure symptoms

Other failures may occur that deal with the Power, Output, or Alarms. Refer to the controller failure symptom in Table 7-4 to determine what is wrong and the troubleshooting procedures to use to correct the problem.

Check installation

If a set of symptoms still persists, refer to *Section 2 - Installation* and ensure proper installation and proper use of the controller in the system.

Determining the software version

Table 7-1 lists the procedure for identifying the software version number.

Table 7-1 Procedure for Identifying the Software Version

Step	Operation	Press	Result
1	Select STATUS Set Up Group	SET UP	<i>Upper Display</i> = READ <i>Lower Display</i> = STATUS
2	Read the software version	FUNCTION	You will see: <i>Upper Display</i> = Software version number <i>Lower Display</i> = A2xx Limit Controller

7.3 Power-up Tests

What happens at power-up

When the controller is powered-up, the EHL023 software to ensure memory integrity runs three tests.

Test failures

If any of these three tests fail, TEST will appear momentarily in the upper display, and a message indicating which test failed will appear in the lower display. (see 7.4). Then “DONE” will appear in the lower display.

7.4 Status Tests

Introduction

When required, the results of these tests can be checked to determine the reason the controller has gone to Failsafe.

How to check the status tests

The procedure in Table 7-2 tells you how to display the results of the status tests.

Table 7-2 Procedure for Displaying the Status Test Results

Step	Operation	Press	Result
1	Select STATUS Set Up Group	SET UP	Upper Display = READ Lower Display = STATUS
2	Read the test results	FUNCTION	You will see: Upper Display = NO or YES YES indicates a failure Lower Display = FAILSF
		FUNCTION	Upper Display = PASS or FAIL Lower Display = TEST

7.5 Background Tests

Introduction

The EHL023 performs ongoing background tests to verify data and memory integrity. If there is a malfunction, an error message will be displayed (blinking) in the lower display.

In the case of simultaneously malfunctions, the messages will appear in sequence in the lower display. Table 7-3 lists these background tests, the reason for their failure, and how to correct the problem.

Table 7-3 Background Tests

Lower Display	Reason for Failure	How to Correct the Problem
EEFAIL	Unable to write to non-volatile memory. Anytime you change a parameter and it is not accepted, you will see EE FAIL.	<ol style="list-style-type: none"> 1. Check the accuracy of the parameter and re-enter. 2. Try to change something in configuration. 3. Run through STATUS tests to re-write to EEPROM.
FAILSF	<p>This error message shows whenever the controller goes into a Failsafe mode of operation. This will happen if:</p> <ul style="list-style-type: none"> • RAM test failed • Configuration test failed • Calibration test failed • Burnout configured for none and the input failed. 	<ol style="list-style-type: none"> 1. Run through STATUS check to determine the reason for the failure. 2. Press the [SET UP] key until STATUS appears in the lower display. 3. Press the {FUNCTION} key to see whether the tests pass or fail, then run through the STATUS codes a second time to see if the error cleared.
IN1FL	<p>Two consecutive failures of input 1 integration; i.e., cannot make analog to digital conversion. This will happen if:</p> <ul style="list-style-type: none"> • Upscale or Downscale burnout is selected • Input not configured correctly 	<ol style="list-style-type: none"> 1. Make sure the actuation is configured correctly. See <i>Section 4 - Configuration</i>. 2. Make sure the input is correct. 3. Check for gross over-ranging. Check S101 jumper position. See Figure 2-2 Jumper Placements 4. Replace factory calibration. See <i>Section 6.6</i>.
CNFERR	<ul style="list-style-type: none"> • PV low limit is > PV high limit • SP low limit is > SP high limit • Output low limit > Output high limit 	<ol style="list-style-type: none"> 1. Check the configuration for each item and reconfigure if necessary.
IN1RNG	Input 1 out of range. The process input is outside the range limits.	<ol style="list-style-type: none"> 1. Make sure the range and actuation are configured properly. 2. Check the input source. 3. Restore the factory calibration. (See <i>Subsection 6.6</i>.) 4. Field calibrate. See <i>Section 6- Input Calibration</i>.
PV LIM	<p>PV out of range. $PV = INP1 + INP1 \text{ BIAS}$</p>	<ol style="list-style-type: none"> 1. Make sure the input signal is correct. 2. Make sure the Bias settings are correct. 3. Recheck the calibration. Use Bias of 0.0

7.6 Controller Failure Symptoms

Introduction

In addition to the error message prompts, there are failure symptoms that can be identified by noting how the controller displays and indicators are reacting.

Symptoms

Compare your symptoms with those shown in Table 7-4.

Table 7-4 Controller Failure Symptoms

Upper Display	Lower Display	Indicators	Controller Output	Probable Cause	Trouble-shooting Procedure
Blank	Blank	Off	None	Power Failure	1
OK	Displayed Output disagrees with controller output	OK	Controller Output disagrees with displayed output	Relay Output	2
OK	OK	OK	External Alarm function does not operate properly	Malfunction in alarm output	3
Display does not function when a key is pressed				Keyboard Malfunction	4

Other symptoms



If a set of symptoms or prompts other than the one you started with appears while troubleshooting, re-evaluate the symptoms. This may lead to a different troubleshooting procedure.

If the symptom still persists, refer to the installation section in this manual to ensure proper installation and proper use of the controller in your system.

7.7 Troubleshooting Procedures

Introduction

The troubleshooting procedures are listed in numerical order as they appear in Table 7-4. Each procedure lists what to do if you have that particular failure and how to do it or where to find the data needed to accomplish the task.

 WARNING—SHOCK HAZARD 
TROUBLESHOOTING MAY REQUIRE ACCESS TO HAZARDOUS LIVE CIRCUITS, AND SHOULD ONLY BE PERFORMED BY QUALIFIED SERVICE PERSONNEL. MORE THAN ONE SWITCH MAY BE REQUIRED TO DE-ENERGIZE UNIT BEFORE SERVICING.
Failure to comply with these instructions could result in death or serious injury.

Equipment needed

You will need the following equipment in order to troubleshoot the symptoms listed in the tables that follow:

- Calibration sources – T/C, mV, Volt, etc.
- Voltmeter

Procedure #1

Table 7-5 explains how to troubleshoot power failure symptoms.

Table 7-5 Troubleshooting Power Failure Symptoms

Step	What to do	How to do it
1	Check the AC line voltage.	Use a voltmeter to measure the AC voltage across terminals L1 and L2 on the rear terminal panel of the controller. Check the earth ground connection.
2	Make sure the chassis plugs into the rear of the case properly.	Withdraw the chassis and visually inspect the controller board and the inside of the case.
3	Check the system for Brown-outs, heavy load switching, etc., and conformance to installation instructions.	Refer to <i>Section 2 - Installation</i> .
4	Change Main board.	Installation instructions supplied with new board.

Procedure #2

Table 7-6 explains how to troubleshoot Latching Output Relay failure.

Table 7-6 Troubleshooting Latching Output Relay Failure

Step	What to do	How to do it
1	Make sure all the configurable data stored in the controller is correct. Reconfigure, if necessary.	Refer to <i>Section 4 - Configuration</i> to check all this data and how to reconfigure.
2	Check that the Latching Relay actuates properly.	Move the setpoint above or below the PV value, depending on the type of Limit Control configured. Listen for the click of the relay as the setpoint is moved above or below the PV.
3	Check the Latching Relay jumper position (NO or NC).	Refer to <i>subsection 2.4 Limit Control and Alarm Relay Contact Information</i> for Relay Contact information.

Procedure #3

Table 7-7 explains how to troubleshoot Alarm Relay Output failure.

Table 7-7 Troubleshooting Alarm Relay Output Failure

Step	What to do	How to do it
1	Check the alarm configuration data. If it is correct, check the field wiring.	Reconfigure if necessary. Refer to <i>Section 4 - Configuration</i> for details.
2	Check that the applicable alarm relay actuates properly depending on what you have set at prompt AxSxTYPE. If it does, check the field wiring.	If the alarm type is set for PV, place the controller in manual mode. Vary the input to raise and lower the PV around the setpoint. Listen for a click from the relay as the PV moves in either direction and note that the proper ALM1 or ALM2 is lit. EXAMPLE: If the alarm is set for MAN, put the controller into manual mode. The alarm light is ON. Put the controller into automatic mode and the alarm light is OFF.
3	Check the contacts.	Make sure the NO or NC contact wiring is correct. Refer to <i>Section 2 - Installation</i> for relay jumper placement and relay contact information.
4	Change Main board.	Installation instructions supplied with new board.

Procedure #4

Table 7-8 explains how to troubleshoot a Keyboard failure.

Table 7-8 Troubleshooting a Keyboard Failure

Step	What to do	How to do it
1	Make sure the keyboard is connected properly.	Withdraw the chassis from the case and visually inspect the connection.
2	Controller Keyboard or specific keys may be LOCKED OUT via the security code.	Use your four-digit security code number to change the lockout level. Refer to <i>Section 4 – Configuration</i> .
		NOTICE
		Using “1000” as a security code number will override the 4-digit code previously entered.
3	Replace the display/keyboard if any keys are not functioning.	Installation instructions supplied with new display/keyboard.

8 Parts List

8.1 Exploded View

Introduction

Figure 8-1 is an exploded view of the EHL023 Limit Controller. Each part is labeled with a key number. The part numbers are listed by key number in Table 8-1. Parts not shown are listed in Table 8-2.

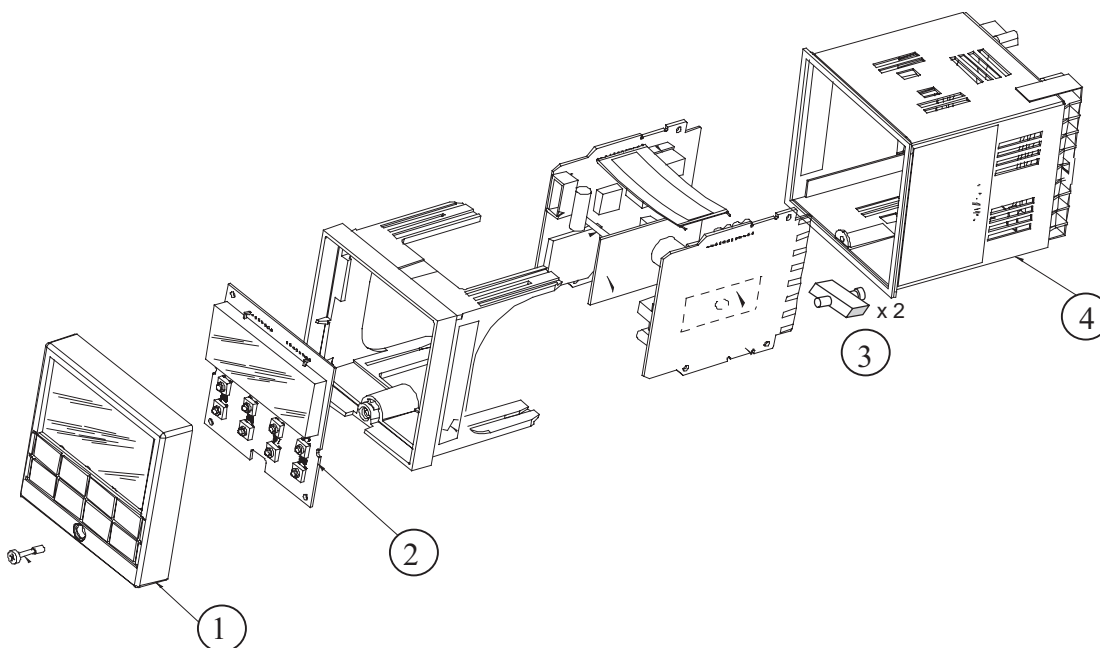

Figure 8-1 EHL023 Exploded View

Table 8-1 Parts Identification

Key Number	Part Number	Description
1	30756667- 551	Bezel Assembly (GREEN)
2	51309766-501	Display/Keyboard
3	30755050-001	Mounting Kit
4	51404896-501	Case Assembly (includes 30755050-001 Mounting Kit)

Table 8-2 Parts Not Shown

Part Number	Description
30755223-003	DIN Adapter (Gray)
30756683-001	NEMA 3 Gasket (Panel to Case)
30755050-001	Mounting Kit
30757215-001	NEMA 4 Adapter Kit
30756764-002	Rear Terminal Cover Kit
30754465-501	0-10 Volt Input resistor assembly (100K pair)
30754142-003	Terminal Strip Assembly
30755306-501	Electro-mechanical Relay (5 Amp)

9 Index

A

Accuracy, 12
Alarm 2Relay Action, 14
Alarm Blocking, 33
Alarm Hysteresis, 33
Alarm Relay Contact Information, 15
Alarm Relay Output Failure, 60
Alarm Setpoints, 41
Alarm Setpoints, 41
Alarms Set Up Group, 32
Alarmx Setpoint X State, 32
Alarmx Setpointx Type, 32
Alarmx Setpointx Value, 32
Annunciators, 38
Application Related Problems, 53

B

Background Tests, 55
Bias On Input 1, 29
Burnout Protection, 30

C

Calibration Mode, 49, 51
Calibration Steps, 43
CE Conformity, 12
CE Conformity (Europe), 10
Cold Junction Temperature, 50
Communications Set Up Group, 31
Communications State, 31
Composite Wiring Diagram, 19
Configuration, 24
Configuration Lockout, 27
Configuration Procedure, 26
Configuration Prompt Hierarchy, 25
Configuration Record Sheet, 34
Control/Alarm Circuit Wiring, 18
Controller Failure Symptoms, 57
Controller Grounding, 18

D

Decimal Point Selection, 29
Dimensions, 16
Display Mode, 38
Displays And Indicators, 36
DOWNSCALE BURNOUT, 30

E

EHL023 Limit Controllers, 9
Electrical Considerations, 18
Electrical Noise Precautions, 18
Electromechanical Relay Output, 21
Emissivity, 30
EMISSIVITY, 30
Equipment You Will Need To Calibrate, 45
Error Messages, 39
Exploded View, 61
External Wiring, 18

F

Factory Calibration, 50
Field Wiring, 44
Filter For Input 1, 30
Function Prompts, 25

H

High And Low Limit Indication, 39
High Limit Controller, 9
HIGH SETPOINT LIMIT, 28

I

Initial Start-Up, 22
Input 1 Actuation Type, 29
Input 1 Calibration Procedure, 48, 49
Input 1 Connections, 20
Input 1 High Range Value, 29
Input 1 Low Range Value, 29
Input 1 Set Up Group, 29
Input 1 Set Up Wiring, 46
Input 1 Wiring Terminals, 44
Input Calibration, 42
Input I Jumper Placement, 14
Installation, 11
Installation Related Problems, 53
Internal Jumper (W101) For CONTROL, 14

J

Jumper For Input 1, 45

K

Key Error, 37
Key Error Message, 23

Key Functions, 23
Keyboard Failure, 60

L

Latching Alarm For Output, 33
Limit Control And Alarm Relay Contact Information, 15
Limit Control Application Diagram, 21
Limit Control Relay Contact Information, 15
Limit Control Relays, 15
Limit Controller Wiring, 21
Limit Set Up Group, 28
Lock Set Up Group, 27
Lockout Feature, 37
Lockout Levels, 37
Low Limit Controller, 9
LOW SETPOINT LIMIT, 28

M

Mains Power Supply, 18, 20
Milliamperes, Millivolt, Volts, And Radiamatic, 45
Minimum And Maximum Range Values, 43
Model Number Interpretation, 13
Monitoring Your Limit Controller, 38
Mounting, 16
Mounting Method, 17
Mounting Procedure, 17

N

Normal Display, 28

O

Operating Limits, 12
Operating Principles, 40
Operating The Limit Controller, 35
Operating Your Limit Controller, 40
Operator Interface, 10, 23, 36
Options Set Up Group, 31

P

Parts Identification, 61
Parts List, 61
Permissible Wiring Bundling, 19
Physical Considerations, 16
Power Failure Symptoms, 59
Power Line Frequency, 30
Power Up Logic, 28, 40
Powering Up, 22
Power-Up Tests, 54

Pre-Installation Information, 12
Preliminary Checks, 13

R

Range Values, 43
Relay Contacts, 41
Reset The Latching Relay, 40
RTD (Resistance Thermometer Device), 45
RTD Inputs, 47

S

Security Code, 27, 36
Security Code Entry, 37
Set Up Group, 25
Shock Hazard Warning, 58
Software Version Number, 54
SP High Limit, 28
SP Low Limit, 28
Specifications, 12
Start Up, 22
Status Tests, 55
Suppression Devices, 18

T

Temperature Units, 29
Test Failures, 54
Test Failures, 22
Thermocouple Inputs (Ice Bath), 45
Thermocouple Inputs (T/C Source), 45
Thermocouple Inputs Using A Thermocouple Source, 46
Thermocouple Inputs Using An Ice Bath, 46
Time Proportional Output Failure, 59
Timing Out From Lower Display, 38
Troubleshooting Aids, 53
Troubleshooting Procedures, 58
Troubleshooting/Service, 52
Type Of Limit Controller, 28

U

UPSCALE BURNOUT, 30

V

Viewing The Operating Parameters, 38
Voltage And Resistance Equivalents For 0% And 100% Range Values, 43

W

WARNING—SHOCK HAZARD, 58

Wiring, 18

Wiring Bundling, 19

Wiring Connections For 0 To 10 Volts, 48

Wiring Connections For Radomatic, Milliampere,
Millivolts, Or Volts (Except 0 To 10 Volts), 48

Wiring Connections For RTD (Resistance
Thermometer Device), 47

Wiring Diagrams, 19



Offered By:

Power Equipment Company
2011 Williamsburg Road
Richmond, Virginia 23231
Phone (804) 236-3800
Fax (804) 236-3882

www.peconet.com